

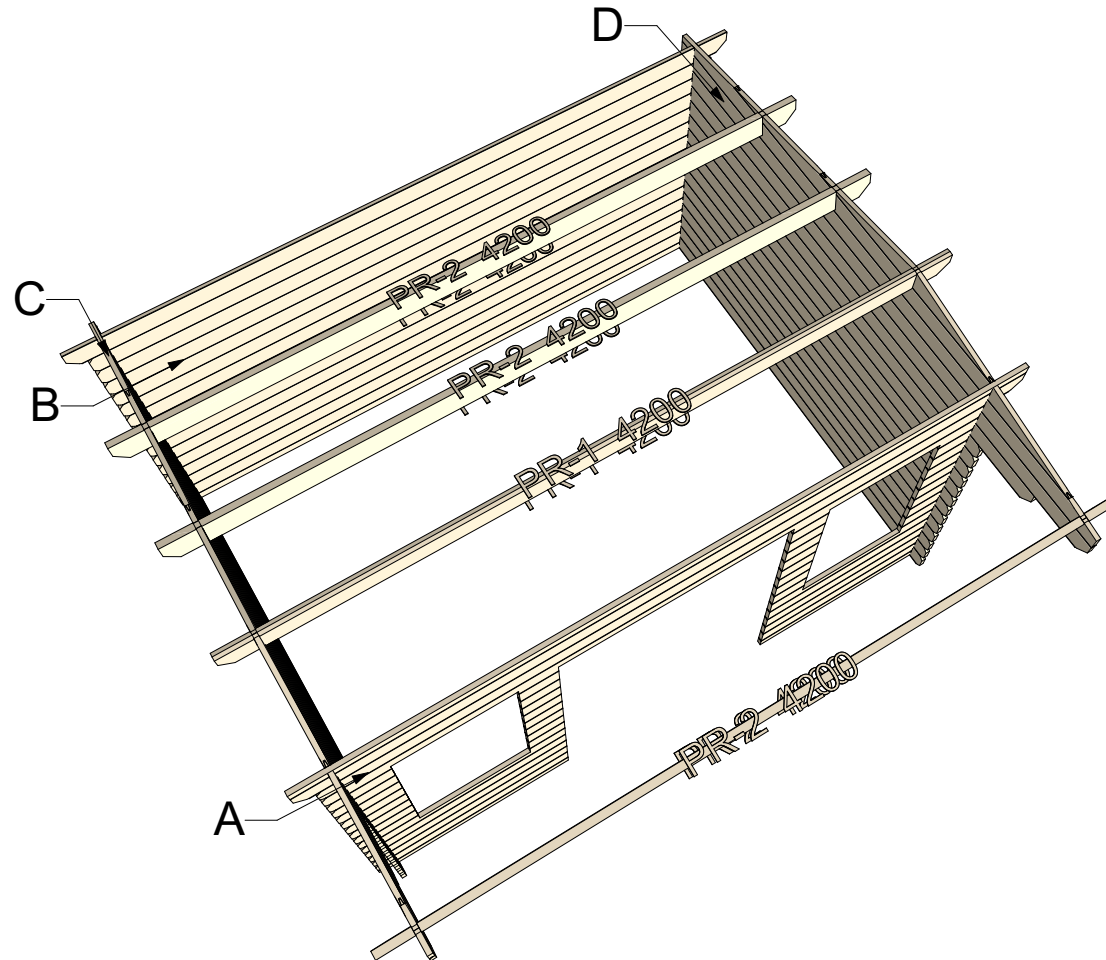

28 Ramsgate 4x3

Walls and purlins positions



Thickness:	Project name:	Project ID:	Year:	Page:
28	Ramsgate 4x3		2022	2

Floor bearers plan

1:50

Floor boards plan

1:50

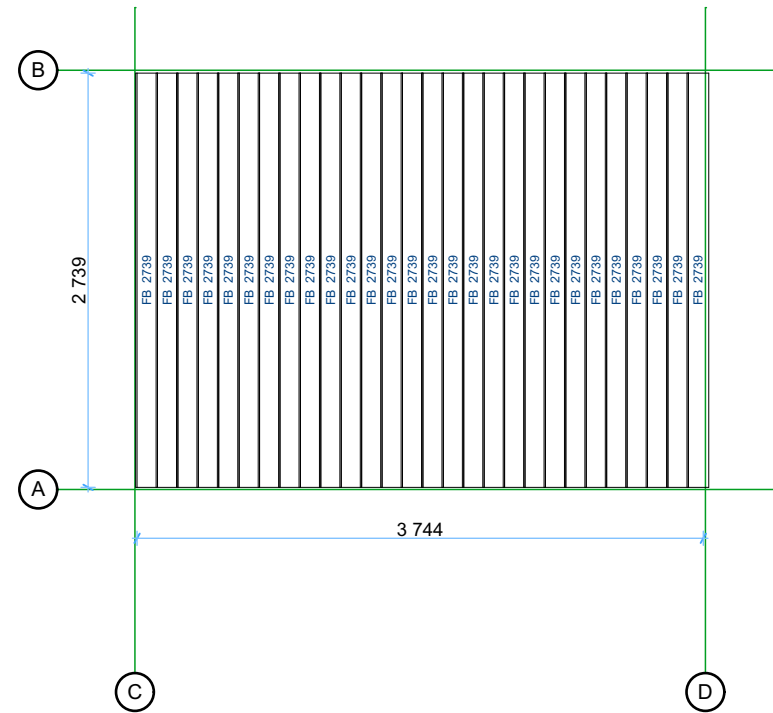
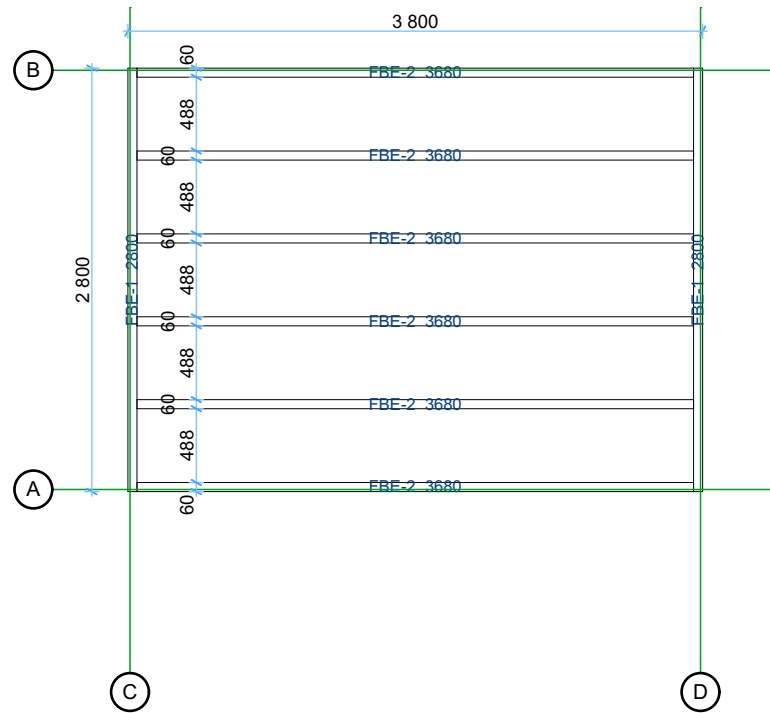

Thickness:	Project name:	Project ID:	Year:	Page:
28	Ramsgate 4x3		2022	3

Ground floor plan

1:50 Roof boards

1:50

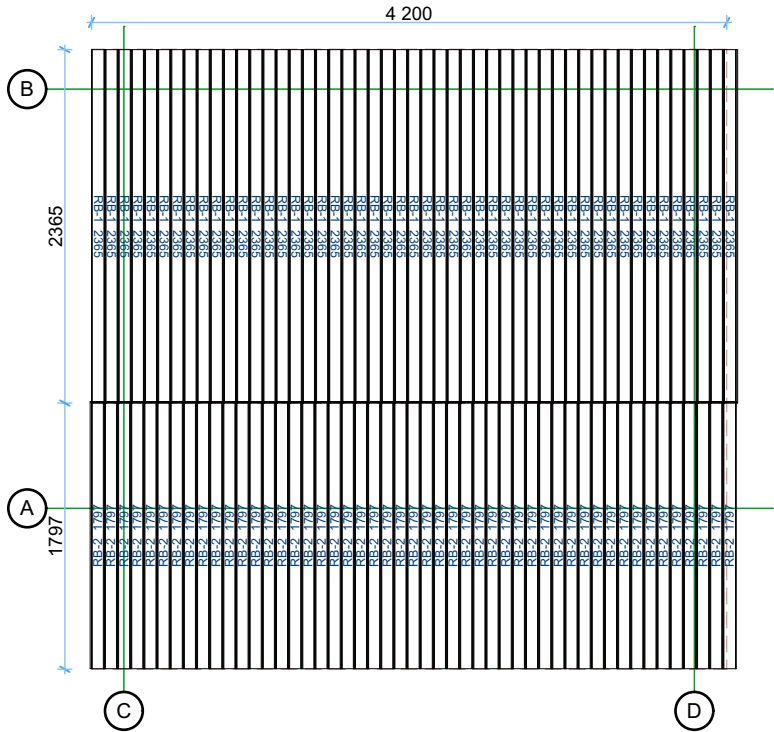
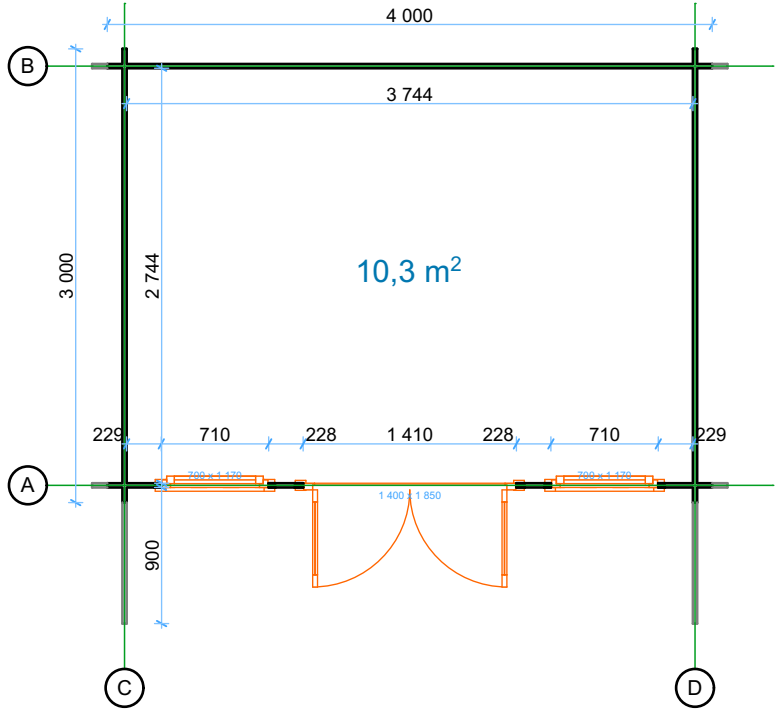

Thickness:	Project name:	Project ID:	Year:	Page:
28	Ramsgate 4x3		2022	4

Wall A

1:50

Wall B

1:50

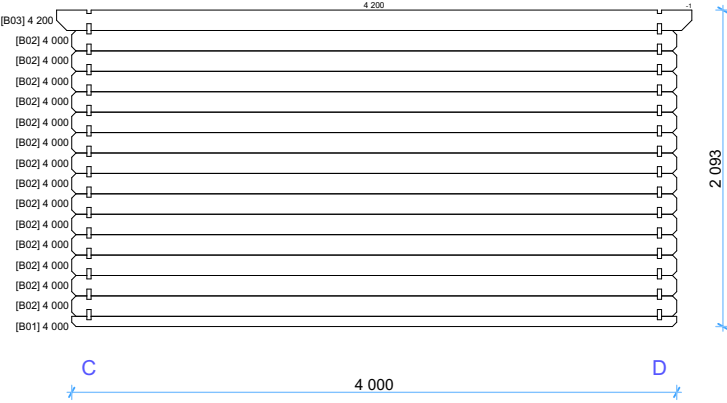
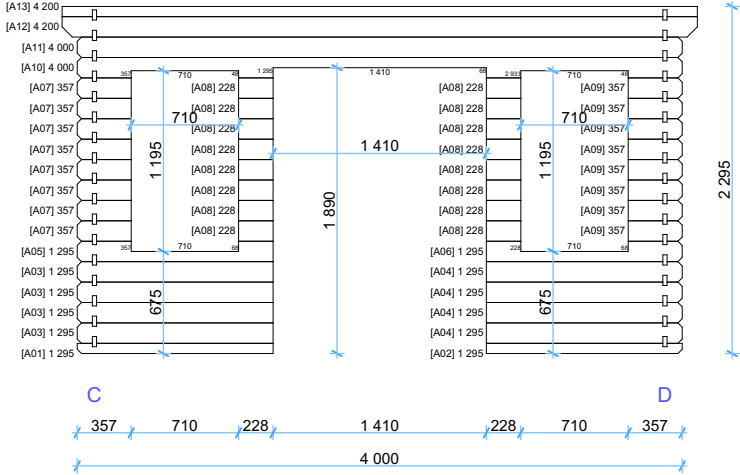

Thickness:	Project name:	Project ID:	Year:	Page:
28	Ramsgate 4x3		2022	5

Wall C

1:50

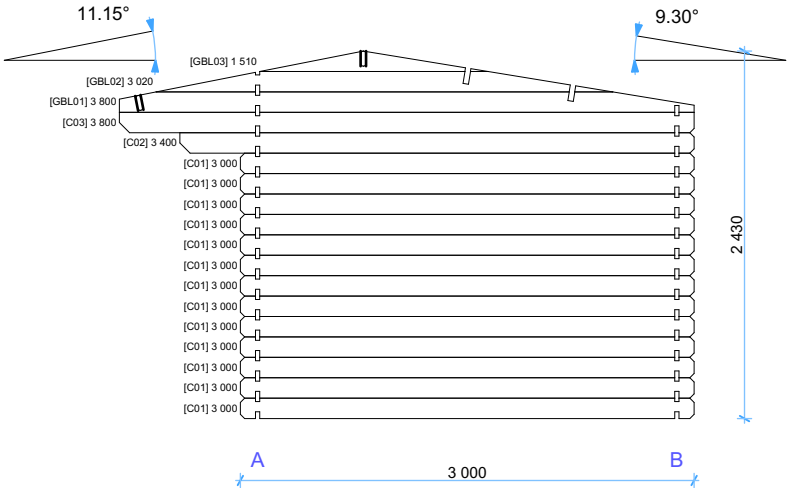

Wall D

1:50

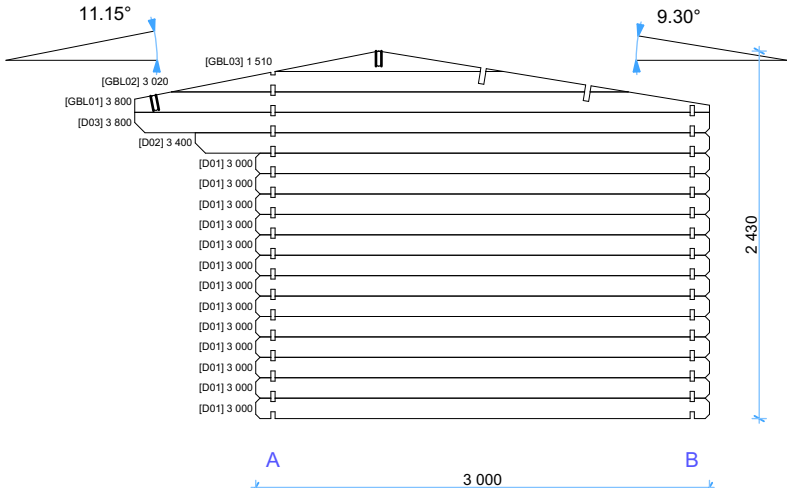

Thickness:	Project name:	Project ID:	Year:	Page:
28	Ramsgate 4x3		2022	6

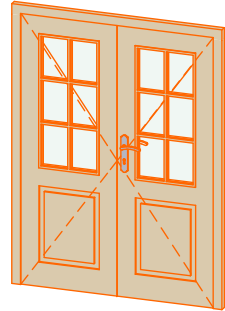
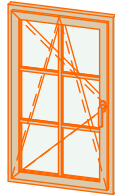
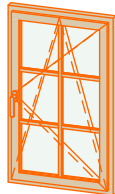
Windows and doors list							
Type-quality	Barcode	Wall Thickness	W x H Size	Orientation	Glazing	Quantity	3D Axonometry
Door - Economy	DG185140-2	28	1 400×1 850	R	50% glass, double glazed	1	
Window - Economy	DG11770	28	700×1 170	L	Double glazed	1	
Window - Economy	DG11770	28	700×1 170	R	Double glazed	1	

Thickness:	Project name:	Project ID:	Year:	Page:
28	Ramsgate 4x3		2022	7